

# Locker Installation & Assembly Instructions

## Cora Bike Rack - Double Tier Locker (CBL-DT) Upper rack modification

Note this modification should be completed prior to commencing CBL-DT assembly

Components needed to make modification

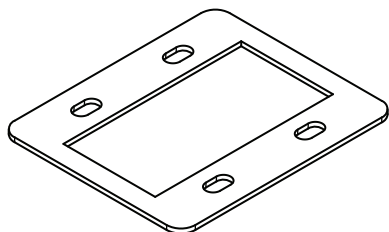

spacer plate (x2)

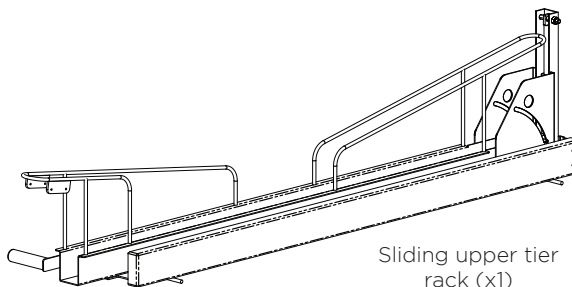

Sliding upper tier rack (x1)

To attach the spacer plates the bolts are included with the sliding upper tier rack. If these components are not long enough additional longer u-bolts have been supplied with spacers.

1. Position the rack so that you can access the underside locate the guide wheel and 2 u-bolts

Unscrew and remove u-bolts keep u-bolts and nuts handy to assemble spacer plates

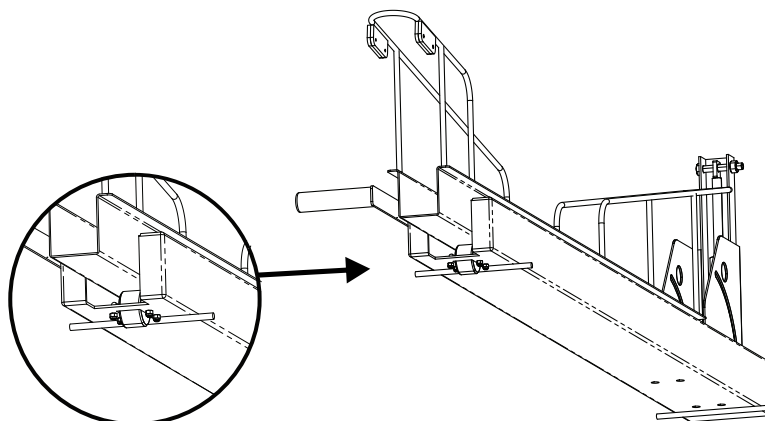

2. Attach the spacer plates

**Note: The sliding upper bike hold has been removed from the following images for clarity purposes.**

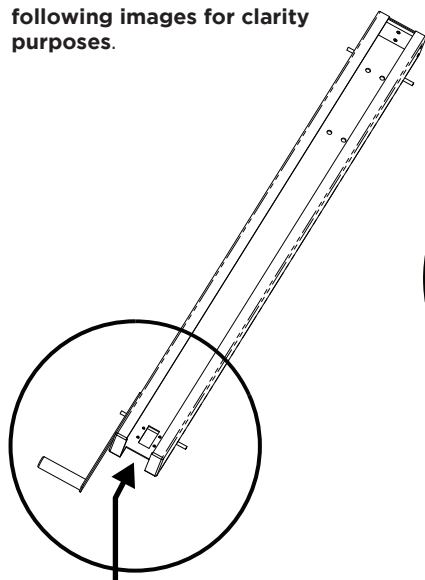

1. Remove guide wheel and axle

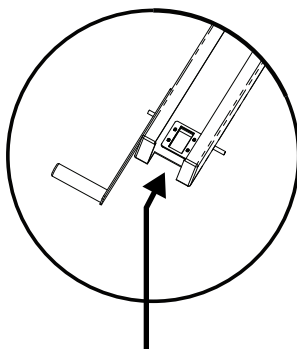

2. Stack two spacer plates in position over bolt holes (on the inside of the rack)

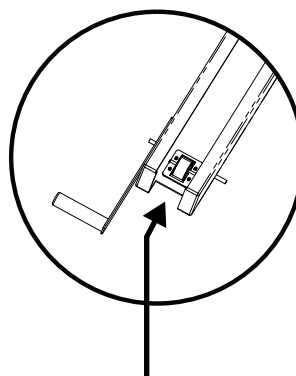

3. Reassemble wheel and axle (axle rests on top face of stacked spacers)

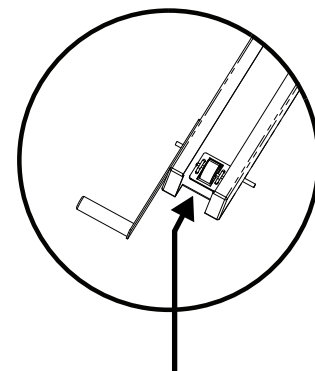

2. Insert the u-bolts back into the holes from the top and secure spacer plates on the underside with nuts.